

Electricity

Class 10 Science Electricity Very Short Answer Type Questions [1 Mark] – Year 2015

1. Write S.I. unit of resistivity.

Answer. Ohm-metre (Ωm).

Class 10 Science Electricity Short Answer Type Questions[III] [3 Marks] – Year 2015

2.(i) Draw a closed circuit diagram consisting of a 0.5 m long nichrome wire XY, an ammeter, a voltmeter, four cells of 1.5 V each and a plug key.

(ii) Following graph was plotted between V and I values :

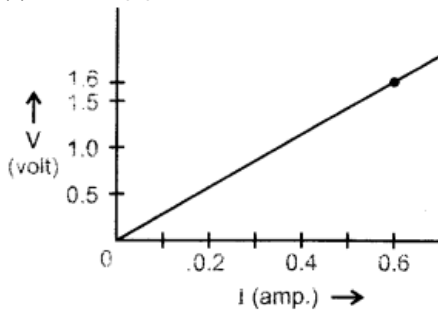

What would be the values of V/I ratios when the potential difference is 0.8 V, 1.2 V and 1.6 V respectively? What conclusion do you draw from these values?

Answer.

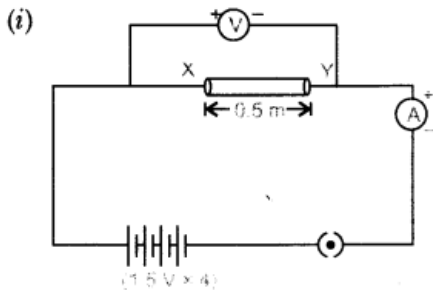

(ii) From the graph, when p.d is 1.6 volt and 0.6 A current.

$$\frac{V}{I} = \frac{1.6}{0.6} = 2.67 \Omega.$$

Therefore, value of $\frac{V}{I}$ ratio for all potential difference of 0.8 V, 1.2 V and 1.6 volt will be equal to 2.67 Ω .

We conclude that at the given temperature, the resistance of wire is constant and is equal to 2.67 Ω .



3. Study the following electric circuit and find (i) the current flowing in the circuit and (ii) the potential difference across $10\ \Omega$ resistor.

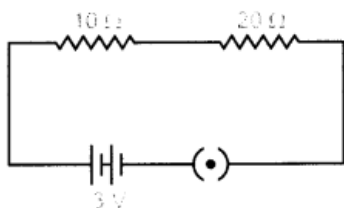

Answer.

$10\ \Omega$ and $20\ \Omega$ are connected in series, their equivalent resistance is

$$\begin{aligned} R_s &= R_1 + R_2 \\ &= 10 + 20 = 30\ \Omega \end{aligned}$$

(i) Current flowing in the circuit

$$\begin{aligned} I &= \frac{V}{R_s} = \frac{3}{30} \\ &= \frac{1}{10} = 0.1\ \text{A} \end{aligned}$$

(ii) Potential difference across $10\ \Omega$ resistor

$$\begin{aligned} V &= IR \\ &= \frac{1}{10} \times 10 = 1\ \text{volt.} \end{aligned}$$

4. Find the current drawn from the battery by the network of four resistors shown in the figure.

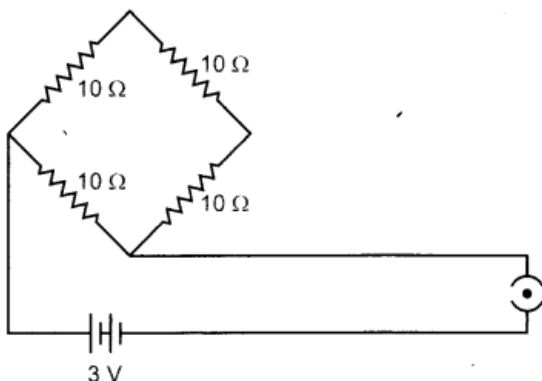

Answer.

Equivalent resistance the given network is

$$\begin{aligned} \frac{1}{R} &= \frac{1}{R_4} + \frac{1}{R_1 + R_2 + R_3} \\ &= \frac{1}{10} + \frac{1}{10 + 10 + 10} = \frac{1}{10} + \frac{1}{30} = \frac{3+1}{30} = \frac{4}{30} \end{aligned}$$

$$\therefore R = \frac{30}{4} = 7.5\ \Omega$$

Current drawn from the battery

$$I = \frac{V}{R} = \frac{3}{7.5} = \frac{30}{75} = \frac{2}{5}$$

$$\Rightarrow I = 0.4\ \text{A}$$

5. What is meant by electric current? Name and define its SI unit. In a conductor electrons are flowing from B to A. What is the direction of conventional current? Give justification for your answer.

A steady current of 1 ampere flows through a conductor. Calculate the number of electrons that flows through any section of the conductor in 1 second. (Charge on electron 1.6×10^{-19} coulomb).

Answer.

- Electric Current: The amount of charge 'Q' flowing through a particular area of cross section in unit time 't' is called electric current, i.e.
- Electric current, $I = Q/t$
- SI unit of electric current is ampere.
- One ampere of current is that current which flow when one coulomb of electric charge flowing through a particular area of cross-section of the conductor in one second, i.e. $1A = 1 \text{ Cs}^{-1}$.
- The direction of conventional current is A to B, i.e. opposite to the direction of flow of electrons. In a metal, flow of electrons carrying negative charge constitutes the current. Direction of flow of electrons gives the direction of electronic current by convention, the direction of flow of positive charge is taken as the direction of conventional current.
Charge = $q = ne$

$$\text{For } q = 1 \text{ coulomb, } n = \frac{1\text{C}}{1.6 \times 10^{-19} \text{ C}} = \frac{10^{19}}{1.6} = 6.25 \times 10^{18} \text{ electrons}$$

6. What is meant by electrical resistivity of a material? Derive its S.I. unit. Describe an experiment to study the factor on which the resistance of a conducting wire depends.

Answer. Mathematically, resistivity of the conducting material is given by

$$\rho = R \times A/J$$

$$\text{If } l = 1 \text{ m, } A = 1 \text{ m}^2, \text{ then } \rho = R$$

Hence, the resistivity of the material is defined as the resistance offered by a metallic wire having a unit length and a unit area of cross-section. Since unit length and unit area of cross-section forms a cube, the specific resistance or resistivity can also be defined as the resistance offered by a cube of a material of side 1 m when current flows perpendicularly through the opposite faces. In SI system, its units is

$$\begin{aligned} \text{Unit of } \rho &= \frac{\text{Unit of } R \times \text{Unit of area of cross - section}}{\text{Unit of length of conductor}} \\ &= \frac{\Omega \times \text{m}^2}{\text{m}} = \Omega\text{m} \end{aligned}$$

Experiment:

Aim : To study the factors on which resistance of conducting wires depends. Apparatus Required : A cell, an ammeter, nichrome wires of different length but same area of cross-section (thickness), nichrome wires of same length but different thickness, copper and iron wire of the same length and same thickness as that of any nichrome wire.

Procedure :



1. Connect the cell, an ammeter and plug key in series with nichrome wire of length T (marked 1) in the gap XY as shown.

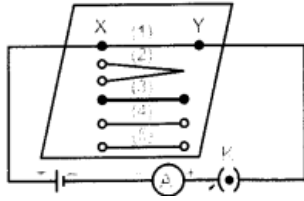

2. Close the key and note the reading of ammeter. It measures the current ' I_1 ' through the nichrome wire (marked '1').
3. Replace the marked 1 wire with another nichrome wire having same area of cross-section (thickness) but of double length ' $2l$ ' (marked 2).
4. Note the ammeter reading (I_2) again after closing the key.
5. Again replace the marked 2 wire with marked 3 wire which has the same length but is thicker than marked 1 and 2 nichrome wires. Again note down the current (I_3) through this wire.
6. Unplug the key. Remove marked 3 nichrome wire from the gap XY. Connect the copper wire marked 4 having same length and same area of cross-section as that of nichrome wire marked 1. .
7. Plug the key again and note the ammeter reading. It measures the current (I_4) through copper wire.
8. Repeat the experiment with iron wire and measure the current (I_5).

Observation :

1. Current ' I_2 ' is half of I_1 i.e., $I_2 = 1/2 I_1$
2. Current I_3 increases when thicker wire of same length and of same material i. e., nichrome is used.
3. Current I_4 and I_5 is different for copper and iron wire.

Conclusion :

1. Different wires draw different amount of current from the same cell.
2. First observation indicates that the resistance of the conductor increases with increase in length. So, resistance is directly proportional to length.
3. Second observation shows that thicker wires have lesser resistance. So, resistance is inversely proportional to area of cross section of the wire.
4. Third observation shows that resistance of the conductor depends on the nature of its material.

7. (a) Write two points of difference between electric energy and electric power. (6) Out of 60 W and 40 W lamps, which one has higher electrical resistance when in use.

(c) What is the commercial unit of electric energy? Convert it into joules.

Answer. (a) Difference between electric energy and electric power:



Electrical energy	Electric power
<p>(i) The work done or energy supplied by the source in maintaining the flow of electric current is called electrical energy. It appears in the form of heat given by</p> $H = VI t = \frac{V^2 t}{R} = I^2 R T$	<p>(i) The time rate at which electric energy is consumed or dissipated by an electrical device is called electric power and is given by</p> $P = VI = \frac{V^2}{R} = I^2 R$
<p>(ii) It is equal to the product of power and time</p> $E = P \times t$	<p>(ii) it equal to the rate of doing work by an energy source.</p> $P = \frac{W}{t}$
<p>(iii) Its SI unit is joule (J) 1 J = 1 W × 1 s</p>	<p>(iii) Its SI unit is watt (W) 1 W = 1 J s⁻¹</p>

(b) For the same applied voltage, $P \propto \frac{1}{R}$

i.e. less the power of electrical device, higher is its electrical resistance.

(c) Kilowatt hour – Commercial unit of electrical energy

$$1 \text{ kWh} = 1000 \text{ Wh} = 1000 \text{ J/S} \times 3600 \text{ sec}$$

$$= 3600000 \text{ J} = 3.6 \times 10^6 \text{ J}$$

8.State Ohm's law. Write the necessary conditions for its validity. How is this law verified experimentally? What will be the nature of graph between potential difference and current for a conductor? Name the physical quantity that can be obtained from this graph.

Answer. Ohm's law : When the physical conditions such as temperature etc. remain same, the current flowing through the conductor is directly proportional to the potential difference applied across the ends of the conductor, i.e.,

$$I \propto V \text{ or } V \propto I$$

$$\Rightarrow \frac{V}{I} = \text{constant}$$

$$\Rightarrow V = IR$$

where R is constant of proportionality and is called resistance of the wire.

Necessary condition for validity of Ohm's law is that physical condition such as temperature of the conductor remains same.

Procedure:

(i) Complete the circuit by connecting one cell in the gap XY. Plug the key.

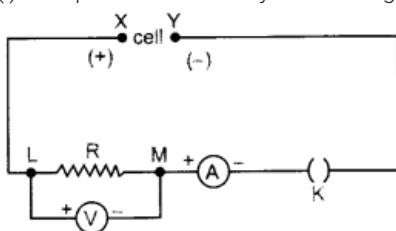

(ii) Note the reading in the ammeter for the current I and in the voltmeter for the potential difference, (V) across the nichrome wire.

(iii) Repeat the above steps using two cells in series (⊕|⊖|⊕|⊖) and then three cells in the series (⊕|⊖|⊕|⊖|⊕|⊖) in the gap XY separately.

(iv) Tabulate the readings in the table given :

S. No.	No. of cells in gap XY	Voltmeter reading V (Volt)	Ammeter reading I (ampere)	V I (Volt ampere)
1	1			
2	2			
3	3			

(v) Find the ratio of V to I for each observation.

(vi) Plot a graph between V (y-axis) and I (x-axis).

Observation :

1. Voltmeter and ammeter reading increases as the number > of cells increase in series.
2. Same value of V/I is obtained in each case.
3. V-I graph is a straight line passing through the origin of the graph as shown.

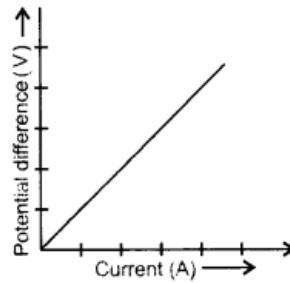

Conclusion : Straight line nature of graph shows that the current is proportional to the potential difference. Hence, Ohm's law verified. The slope of V-I graph gives the value of resistance of the conductor at the given temperature.

Class 10 Science Electricity Very Short Answer Type Question [1 Mark] – Year 2014

9. Name a device that helps to maintain a potential difference across a conductor.

Answer. Cell or battery

Class 10 Science Electricity Short Answer Type Questions [II] [3 Marks] – Year 2014

10. Define 1 volt. Express it in terms of SI unit of work and charge calculate the amount of energy consumed in carrying a charge of 1 coulomb through a battery of 3 V.

Answer. When 1 joule of work is done in carrying 1 coulomb of charge, from infinity to a point in the electric field, then potential at that point is called 1 volt. Potential difference between two points is

$$V = \frac{W}{Q}$$

or

$$\begin{aligned} W &= Q \times V \\ &= 1 \times 3 = 3 \text{ J} \end{aligned}$$

11. V-I graph for two wires A and B are shown in the figure. If both wires are of same length and same thickness, which of the two is made of a material of high resistivity? Give justification for your answer.

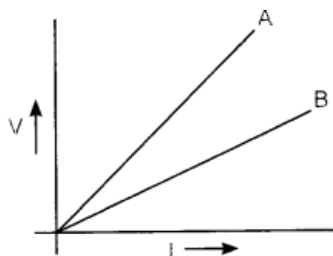

Answer. Greater than slope of V-I graph, greater will be the resistance of given metallic wire. In the given graph, wire A has greater slope than B. Hence, wire A has greater resistance. For the wires of same length and same thickness, resistance depends on the nature of material of the wire, i.e.



$$R_1 = \rho_1 \frac{l}{A} \quad \text{and} \quad R_2 = \rho \frac{l}{A}$$

$$\Rightarrow \frac{R_1}{R_2} = \frac{\rho_1}{\rho_2} \quad \text{or} \quad R \propto \rho$$

Hence, wire 'A' is made of a material of high resistivity.

Class 10 Science Electricity Long Answer Type Questions [5 Marks] – Year 2014

12. Draw a labelled circuit diagram showing three resistors R_1 , R_2 and R_3 connected in series with a battery (E), a rheostat (Rh), a plug key (K) and an ammeter (A) using standard circuit symbol. Use this circuit to show that the same current flows through every part of the circuit. List two precautions you would observe while performing the experiment.

Answer.

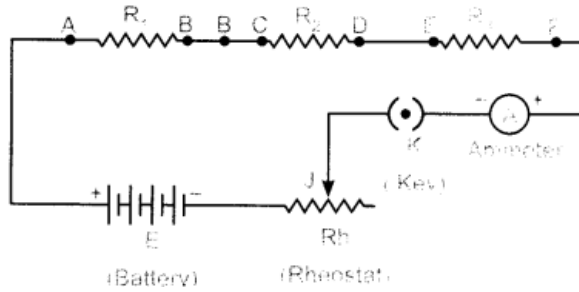

Aim: Same current flows through every part of the above circuit.

Procedure:

1. Connect ammeters, 'A₁' between B and C, and 'A₂' between D and E.
2. Adjust the sliding contact of the rheostat initially for a small current.
3. Note all the ammeter readings. These reading give us current flowing through the resistors **R₁, R₂ and R₃**
4. The current in the circuit is now increased by changing the position of sliding contact J' of the rheostat.
5. Note all the ammeter readings each time.

Conclusion: Same reading of all the ammeter in each observation concluded that same current flows through every part of the circuit.

Precautions:

1. All the connection should be tight and properly connected as per circuit diagram.
2. The positive terminal of the ammeter and voltmeter must be connected to the positive terminal of the battery or battery eliminator.

13. Two wires A and B are of equal length and have equal resistance. If the resistivity of A is more than that of B which wire is thicker and why? For the electric circuit given below calculate:

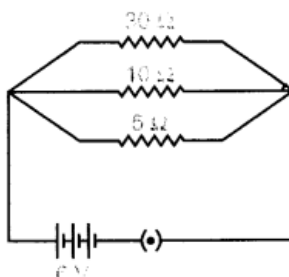

(i) Current in each resistor,



- (ii) Total current drawn from the battery, and
 (iii) Equivalent resistance of the Circuit

Answer.

Using, $R = \rho \frac{l}{A}$

$$\Rightarrow \frac{\rho}{A} = \frac{R}{l} = \text{Constant} = K \text{ (for same } l \text{ and } R)$$

$$\Rightarrow \rho = k A$$

$$\Rightarrow \rho \propto A$$

So, for different materials having same resistance per unit length, greater resistivity material wire has more cross-sectional area.

Hence, wire A is thicker than that of B.

(i) Current through each resistor

$$I_1 = \frac{V}{R_1} = \frac{6}{5} = 1.2 \text{ A}$$

$$I_2 = \frac{V}{R_2} = \frac{6}{10} = 0.6 \text{ A}$$

$$I_3 = \frac{V}{R_3} = \frac{6}{30} = 0.2 \text{ A}$$

Current in 5 Ω , 10 Ω and 30 Ω are therefore, 1.2 A, 0.6 A and 0.2 A respectively.

(ii) Total current drawn from the battery

$$I = I_1 + I_2 + I_3 = 1.2 + 0.6 + 0.2 = 2.0 \text{ A}$$

(iii) $R_1 = 5 \Omega$, $R_2 = 10 \Omega$ and $R_3 = 30 \Omega$ are connected in parallel. So their equivalent resistance

$$\frac{1}{R} = \frac{1}{R_1} + \frac{1}{R_2} + \frac{1}{R_3} = \frac{1}{5} + \frac{1}{10} + \frac{1}{30} = \frac{1}{3}$$

$$R = 3 \Omega$$

14. (a) Define electric power. Express it in terms of potential difference V and resistance R.
 (b) An electrical fuse is rated at 2 A. What is meant by this statement?
 (c) An electric iron of 1 kW is operated at 220 V. Find which of the following fuses that respectively rated at 1 A, 3 A and 5 A can be used in it.

Answer.

(a) Electric power: It is the rate of doing work by an energy source or the rate at which the electrical energy is dissipated or consumed per unit time in the electric circuit is called electric power.

So, $\text{Power } P = \frac{\text{Work done } (w)}{\text{Time } (t)}$

$$= \frac{\text{Electrical energy dissipated}}{\text{Time } (t)}$$

$$= VI = \frac{V^2}{R}$$

(b) It means, the maximum current will flow through it is only 2 A. Fuse wire will melt if the current exceeds 2 A value through it.

(c) Given: $P = 1 \text{ kW} = 1000 \text{ W}$, $V = 220 \text{ V}$

$$\text{Current drawn, } I = \frac{P}{V} = \frac{1000}{220} = \frac{50}{11} = 4.54 \text{ A}$$

To run electric iron of 1 kW, rated fuse of 5 A should be used.

Class 10 Science Electricity Very Short Answer Type Questions [1 Mark] – Year 2013

15. Write relation between heat energy produced in a conductor when a potential difference V is applied across its terminals and a current I flows through for 't'

Answer. Heat produced, $H = VIt$

16. State difference between the wire used in the element of an electric heater and in a fuse wire.

Answer. The wire used in the element of electric heater has a high resistivity and have a high melting point, i.e. even at a high temperature element do not burn while fuse wire have a low melting point and high resistivity.

Class 10 Science Electricity Short Answer Type Questions [3 Marks] – Year 2013

17. The figure below shows three cylindrical copper conductors along with their face areas and lengths. Discuss in which geometrical shape the resistance will be highest.

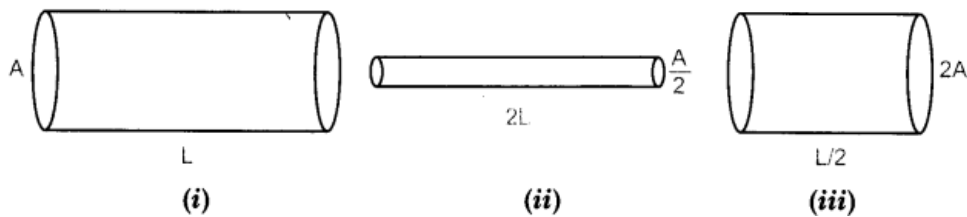

Answer.

For geometrical shape shown in

Figure (i) $R_1 = \rho \frac{L}{A}$

Figure (ii) $R_2 = \rho \frac{2L}{A/2} = 4\left(\rho \frac{L}{A}\right) = 4R_1$

Figure (iii) $R_3 = \rho \frac{L/2}{2A} = \frac{1}{4}\left(\rho \frac{L}{A}\right) = \frac{R_1}{4}$

18. Find the current flowing through the following electric circuit.

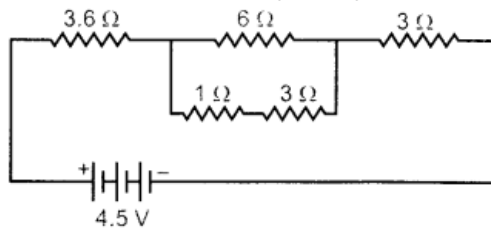

Answer.

Series combination of 1Ω and 3Ω resistance is in parallel combination with 6Ω . Their equivalent resistance is

$$\frac{1}{R_p} = \frac{1}{6} + \frac{1}{3+1} = \frac{1}{6} + \frac{1}{4} = \frac{2+3}{12}$$

$$\therefore R_p = \frac{12}{5} = 2.4 \Omega$$

Now, 3.6Ω , 2.4Ω and 3Ω are in series, their equivalent resistance be

$$R_s = R_1 + R_2 + R_3 \\ = 3.6 + 2.4 + 3 = 9 \Omega$$

Hence, the current flowing through the circuit is

$$I = \frac{V}{R} = \frac{4.5}{9} = \frac{45}{90} = \frac{1}{2} = 0.5 \text{ A.}$$

19. An electric bulb of resistance 200Ω draws a current of 1 Ampere. Calculate the power of the bulb the potential difference at its ends and the energy in kWh consumed burning it for

5h.

Answer. Power of the bulb,

Power of the bulb,

$$P = I^2R = (1)^2 \times 200$$

$$\Rightarrow P = 200 \text{ W}$$

Energy consumed by bulb in 5h in burning = Power \times Time

$$= 200 \times 5$$

$$= 1000 \text{ Wh} = 1 \text{ kWh}$$

Class 10 Science Electricity Long Answer Type Questions [5 Marks] – Year 2013

20. (a) Calculate the resistance of 1 km long copper wire of radius 1 mm. Resistivity of the copper is $1.72 \times 10^{-8} \Omega \text{ m}$.

(b) Draw a schematic diagram of a circuit consisting of a battery of 4 cells of

2V each connected to a key, an ammeter and two resistors of 2Ω and

3Ω respectively in series and a voltmeter to measure potential difference across 3

Answer.

$$(a) \text{ Resistance, } R = \rho \frac{l}{A} = \rho \frac{l}{\pi r^2}$$

On substituting the values, we get

$$R = \frac{1.72 \times 10^{-8} \times 10^3}{3.14 \times (1 \times 10^{-3})^2}$$
$$= \frac{1.72}{3.14} \times 10 = \frac{17.2}{3.14} = 5.47 \Omega$$

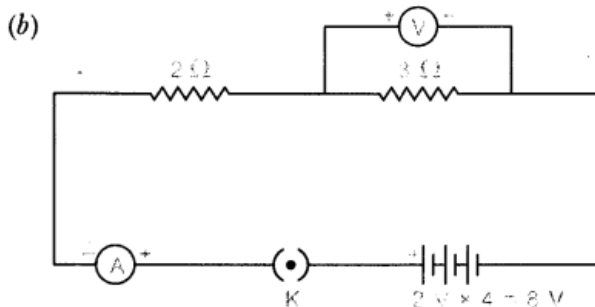

21. When a high resistance voltmeter is connected directly across a resistor its reading is 2 V.

An electric cell is sending the current of 0.4 A, (measured by an ammeter) in the electric

circuit in which a rheostat is also connected to vary the current.

(a) Draw an equivalent labelled circuit for the given data.

(b) Find the resistance of the resistor.

(c) Name and state the law applicable in the given case. A graph is drawn between a set of values of potential difference (V) across the resistor and current (I) flowing through it. Show the nature of graph thus obtained.

Answer.

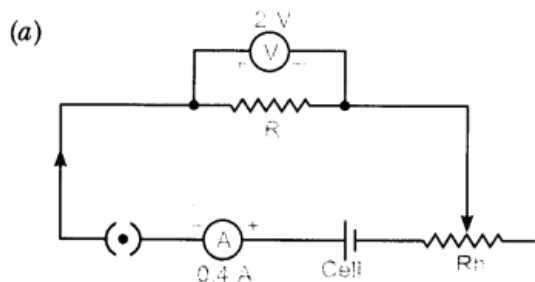

(b) Resistance of resistor is

$$R = \frac{V}{I} = \frac{2}{0.4} = \frac{20}{4} = 5 \Omega$$

(c) Ohm's law : When the physical conditions such as temperature etc. remain same, the current flowing through the conductor is directly proportional to the potential difference applied across the ends of the conductor, i.e.,

$$I \propto V \text{ or } V \propto I$$

$$\Rightarrow \frac{V}{I} = \text{constant}$$

$$\Rightarrow V = IR$$

where R is constant of proportionality and is called resistance of the wire. Since current varies linearly with potential difference, the graph between V and I will be a linear in nature as shown

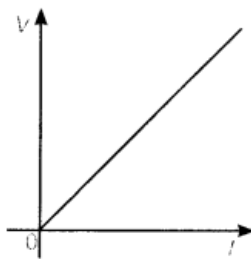

Class 10 Science Electricity Short Answer Type Questions[] [2 Marks] – Year 2012

22. How much current will an electric bulb draw from 220 V source if the resistance of the bulb is 1200Ω? If in place of bulb, a heater of resistance 100 Ω is connected to the sources, calculate the current drawn by it.

Answer.

Given: $V = 220 \text{ V}$, $R_1 = 1200 \Omega$, $I_1 = ?$, $R_2 = 100 \Omega$, $I_2 = ?$

Using Ohm's law,

$$V = I_1 R_1$$

$$\Rightarrow I_1 = \frac{V}{R_1} = \frac{220}{1200} = 0.18 \text{ A}$$

and,

$$I_2 = \frac{V}{R_2} = \frac{220}{100} = 2.2 \text{ A}$$

23. Draw a schematic diagrams of an electric circuit comprising of 3 cells and an electric bulb, ammeter, plug-key in the ON mode and another with same components but with two bulbs in parallel and a voltmeter across the combination.

Answer.



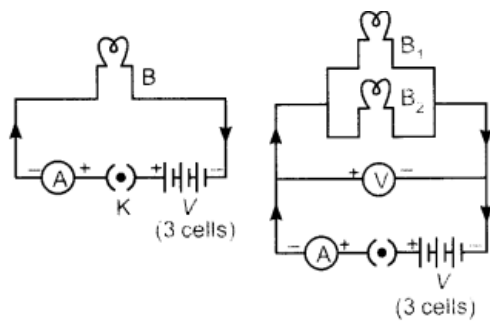

24. Out of the two wires X and Y shown below, which one has greater resistance? Justify your answer.

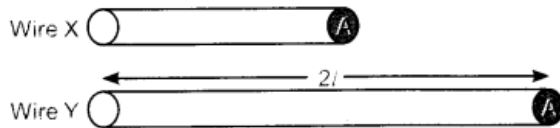

Answer. Wire 'Y' has greater resistance as it has more length than wire 'X'. It is because resistance of wire is directly proportional to the length of wire.

Class 10 Science Electricity Short Answer Type Questions[III] [3 Marks] – Year 2012

25. Two identical wires one of nichrome and other of copper are connected in series and a current (I) is passed through them. State the change observed in the temperatures of the two wires. Justify your answer. State the law which explains the above observation.

Answer. The resistivity of nichrome is more than that of copper so its resistance is also high. Therefore, large amount of heat is produced in the nichrome wire for the same current as compared to that of copper wire. Accordingly, more change in temperature is observed in the nichrome wire. This is explained by Joule's law of heating.

Joule's law of heating: It states that the amount of heat produced in a conductor is

(i) directly proportional to the square of current flowing through it, i.e.
 $H \propto I^2$.

(ii) directly proportional to the resistance offered by the conductor to the current, i.e. $H \propto R$

(iii) directly proportional to the time for which current is flowing through it, i.e.
 $H \propto t$

Combining these, we get

$$H \propto I^2 R t$$

or $H = K I^2 R t$

where K is proportionality constant and in SI system, it is equal to one.

26. An electric bulb is rated at 60 W, 240 V. Calculate its resistance. If the voltage drops to 192 V, calculate the power consumed and the current drawn by the bulb. (Assume that the resistance of the bulb remain unchanged.)

Answer.



Given: $P_1 = 60 \text{ W}$, $V_1 = 240 \text{ V}$, $R = ?$, $P_2 = ?$, $V_2 = 192 \text{ V}$, $I_1 = ?$

Using,
$$P_1 = \frac{V^2}{R}$$

We get
$$R = \frac{V_1^2}{P_1} = \frac{240^2}{60} = 960 \Omega$$

Again
$$P_2 = \frac{V_2^2}{R} = \frac{192 \times 192}{960} = 38.4 \text{ W}$$

Current drawn by bulb at 192 V is

$$I = \frac{V}{R} = \frac{192}{960} = 0.2 \text{ A}$$

Current drawn by bulb at 192 V is

Class 10 Science Electricity Long Answer Type Questions [5 Marks] – Year 2012

27. Three bulbs each having power P are connected in series in an electric circuit. In another circuit, another set of three bulbs of same power are connected in parallel to the same source.

(i) Will the bulbs in both the circuits glow with the same brightness? Justify your answer.

(ii) Now let one bulb in each circuit get fused. Will the rest of the bulbs continue to glow in each circuit? Give reason.

(iii) Representing each bulb by a resistor, draw circuit diagram for each case.

Answer.

(i) Bulbs in parallel provide more illumination. This is because

(a) each bulb gets same voltage and is equal to the applied voltage.

(b) each bulb draws required current from the mains. Hence, they work properly.

(ii) When one bulb in each circuit get fused,

In series: Rest of the bulbs will not glow. This is because in series arrangement, there is only a single path for the flow of current.

In parallel: Rest of the bulbs will continue to glow as in parallel connection,

(a) individual branch in the circuit completes its own circuit, or

(b) different paths are available for the flow of current.

(iii) Circuit diagram

For series,

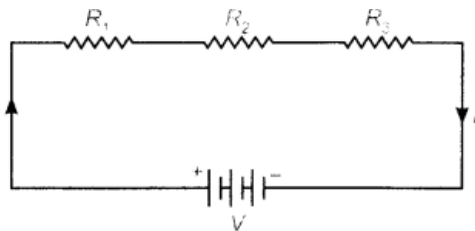

For parallel,

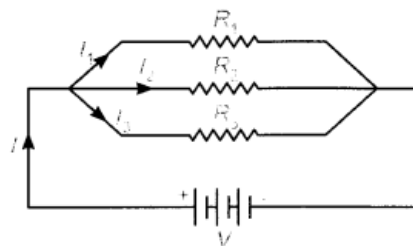

28. (a) Though same current flows through the electric line wires and the filament of bulb, yet only the filament glows. Why?

(b) The temperature of the filament of bulb is 2700°C when it glows. Why does it not get burnt up at such high temperature?

(c) The filament of an electric lamp, which draws a current of 0.25 A is used for four hours. Calculate the amount of charge flowing through the



circuit.

(d) An electric iron is rated 2 kW at 220 V. Calculate the capacity of the fuse that should be used for the electric iron.

Answer. (a) Electric line wires offer extremely low resistance to the flow of current, so they do not glow because negligible heat is produced in it.

The filament of bulb glows because it becomes red hot due to large amount of heat produced, as it offers high resistance to the flow of current through it.

(b) The filament of bulb when it glows at 2700°C does not get burnt because the tungsten metal of filament has

(i) a very high melting point (of 3380°C) and

(ii) a high resistivity.

(c) Given: $I = 0.25 \text{ A}$, $t = 4 \text{ h} = 4 \times 60 \times 60 \text{ sec}$.

So, amount of charge flowing the filament of electric lamp

$$\begin{aligned} q &= It \\ &= 0.25 \times 4 \times 60 \times 60 = 3600 \text{ C} \end{aligned}$$

(d) Given: $P = 2 \text{ kW} = 2000 \text{ W}$, $V = 220 \text{ V}$

Using, $P = VI$

$$2000 = 220 \times I$$

$$\Rightarrow I = \frac{2000}{220} = 9.09 \text{ A}$$

(c) Given: $I = 0.25 \text{ A}$, $t = 4 \text{ h} = 4 \times 60 \times 60 \text{ sec}$.

So, amount of charge flowing the filament of electric lamp

So, the capacity of the fuse that should be used for the electric iron is of the order of 10 A.

29.

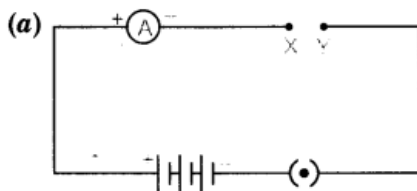

In the given circuit, connect a nichrome wire of length 'L' between points X and Y and note the ammeter reading.

(i) When this experiment is repeated by inserting another nichrome wire of the same thickness but twice the length (2L), what changes are observed in the ammeter reading?

(ii) State the changes that are observed in the ammeter reading if we double the area of cross-section without changing the length in the above experiment. Justify your answer in both the cases.

(b) "Potential difference between points A and B in an electric field is 1 V". Explain the above statement.

- (a) (i) Ammeter reading in the second case is half of the ammeter reading in first case. This is because

$$R \propto l \text{ and } I \propto \frac{1}{R} \quad (V = \text{constant}, A = \text{constant})$$

\Rightarrow i.e. when length is doubled, the resistance is doubled, this means the current is halved.

- (ii) On doubling the area of cross-section without changing the length of the conductor, twice of the previous reading is observed in the ammeter. This is because

$$R \propto \frac{1}{A} \quad (\text{for the same length})$$

$$\text{and } I \propto \frac{1}{R} \quad (\text{for the same voltage})$$

So, when A is double, resistance becomes half, current will be doubled.

Answer. (a)(i) Ammeter reading in the second case is half of the ammeter reading in first case. This is because

\Rightarrow i.e. when length is doubled, the resistance is doubled, this means the current is halved.

(ii) On doubling the area of cross-section without changing the length of the conductor, twice of the previous reading is observed in the ammeter. This is because

So, when A is double, resistance becomes half, current will be doubled. (b) "Potential difference between points A and B in an electric field is 1 V". It means 1 J work is done in moving 1 C of charge from point B to point A in an electric field.

Class 10 Science Electricity Very Short Answer Type Questions [1 Mark] – Year 2011

30. How is an ammeter connected in a circuit to measure current flowing through it?

Answer. In series

31. What happens to resistance of a conductor when its area of cross-section is increased?

Answer.

Resistance decreases as $R \propto \frac{1}{A}$.

32. A given length of a wire is doubled on itself and this process is repeated once again. By what factor does the resistance of the wire change?

Answer. Am. Length becomes one-fourth of the original length and area of cross-section becomes four times that of original.

$$\begin{aligned} \text{i.e.} \quad l_2 &= \frac{1}{4}l_1 \text{ and } A_2 = 4A_1 \\ \therefore \frac{R_2}{R_1} &= \frac{l_2}{l_1} \times \frac{A_1}{A_2} = \frac{1}{4} \times \frac{1}{4} = \frac{1}{16} \\ \Rightarrow R_2 &= \frac{1}{16}R_1 \end{aligned}$$

So, new resistance is (1/16)th of original resistance.

Class 10 Science Electricity Short Answer Type Questions[] [2 Marks] – Year 2011

33. A 9Ω resistance is cut into three equal parts and connected in parallel. Find the equivalent resistance of the combination.

Answer.

$$\text{Resistance of each part} = \frac{R}{3} = \frac{9}{3} = 3 \Omega$$

$$\therefore R_1 = R_2 = R_3 = 3 \Omega$$

In parallel combination,

$$\begin{aligned} \frac{1}{R_p} &= \frac{1}{R_1} + \frac{1}{R_2} + \frac{1}{R_3} \\ &= \frac{1}{3} + \frac{1}{3} + \frac{1}{3} = \frac{3}{3} = 1 \end{aligned}$$

$$\therefore R_p = 1 \Omega$$

34. An electric iron has a rating of 750 W, 220 V. Calculate the (i) current flowing through it, and (ii) its resistance when in use.

Answer.

$$\text{Given: } P = 750 \text{ W, } V = 220 \text{ V}$$

$$(i) \quad P = VI$$

$$750 = 220 \times I$$

$$\Rightarrow I = \frac{750}{220} = 3.40 \text{ A}$$

$$(ii) \quad P = \frac{V^2}{R}$$

$$\Rightarrow R = \frac{V^2}{P} = \frac{220^2}{750} \Rightarrow R = 64.53 \Omega$$

35.(a) What do the following circuit symbols represent?

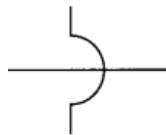

(i)



(ii)

(b) The potential difference between the terminals of an electric heater is 60 V when it draws a current of 4 A from the source. Find the resistance of heater when in use.

Answer.

(a) (i) Wires crossing without touching each other.

(ii) Rheostat/Variable resistor

(b) Given: $V = 60 \text{ V}$, $I = 4 \text{ A}$, $R = ?$

From Ohm's law, $V = IR$

$$60 = 4 \times R = 15 \Omega$$

36. The charge possessed by an electron is 1.6×10^{-19} coulombs. Find the number of electrons that will flow per second to constitute a current of 1 ampere.

Answer.

$$\text{Given: } q = 1.6 \times 10^{-19} \text{ C, } I = 1 \text{ A, } n = ?, t = 1 \text{ s}$$

$$\text{We know, } q = It \text{ and } q = ne$$

$$\therefore ne = It$$

$$\Rightarrow n = \frac{It}{e} = \frac{1 \times 1}{1.6 \times 10^{-19}}$$

$$= 6.25 \times 10^{18} \text{ electrons}$$

37. Explain the role of fuse in series with any electrical appliance in an electric circuit. Why should a fuse with defined rating for an electric circuit not be replaced by one with a larger rating?

Answer. Fuse wire is a safety device connected in series with the live wire of circuit. It has high resistivity and low melting point. It melts when a sudden surge of large current passes through it and disconnects the entire circuit from the electrical supply. But, in case if we use a larger rating instead of a defined rating, then it will not protect the circuit as high current will easily pass through it and it will not melt.

38. The wattage of a bulb is 24 W when it is connected to a 12 V battery. Calculate its effective wattage if it operates on a 6 V battery (Neglect the change in resistance due to unequal heating of the filament in the two cases).

Answer.

Given: $P_1 = 24 \text{ W}$, $V_1 = 12 \text{ V}$, $P_2 = ?$, $V_2 = 6 \text{ V}$

Using $P = \frac{V^2}{R}$

$$\frac{P_1}{P_2} = \frac{V_1^2}{V_2^2}$$

$$\Rightarrow P_2 = \left(\frac{V_2}{V_1}\right)^2 \times P_1 = \left(\frac{6}{12}\right)^2 \times 24 = \frac{1}{4} \times 24 = 6 \text{ W}$$

39. Consider the following circuit diagram. If $R_1 = R_2 = R_3 = R_4 = R_5 = 3 \Omega$, find the equivalent resistance (R_s) of the circuit.

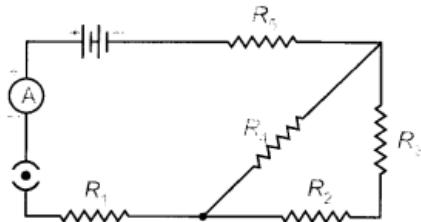

Answer.

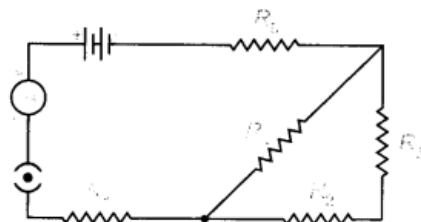

Given : $R_1 = R_2 = R_3 = R_4 = R_5 = 3 \Omega$.

In circuit, R_2 and R_3 are connected in series,

$$\therefore R_{S_1} = R_2 + R_3 = 3 + 3 = 6 \Omega$$

R_{S_1} and R_4 are in parallel

$$\frac{1}{R_p} = \frac{1}{R_{S_1}} + \frac{1}{R_4} = \frac{1}{6} + \frac{1}{3} = \frac{1}{2}$$

$$\therefore R_p = 2 \Omega$$

Now, R_1 , R_p and R_5 are in series so equivalent resistance of the circuit is

$$\begin{aligned} R_s &= R_1 + R_p + R_5 \\ &= 3 + 2 + 3 = 8 \Omega \end{aligned}$$

40. A torch bulb is rated 2.5 V and 750 mA. Calculate (i) its power, (ii) its resistance and (iii) the energy consumed, if this bulb is lighted for four hours.

Answer.

Given: $V = 2.5 \text{ V}$, $I = 750 \text{ mA} = 750 \times 10^{-3} \text{ A}$

$$(i) P = VI = 2.5 \times 750 \times 10^{-3} = 1.875 \text{ W}$$

$$(ii) V = IR$$

$$\therefore R = \frac{V}{I} \\ = \frac{2.5}{750 \times 10^{-3}} = 3.33 \Omega$$

$$(iii) \text{ Energy consumed in four hour by the bulb} = P \times t = 1.875 \times 4 \\ = 7.5 \text{ Wh} = 7.5 \times 10^{-3} \text{ kWh}$$

41. Series arrangements are not used for domestic circuits. List any three reasons.

Answer. Series arrangements are not used for domestic circuit because

1. The electrical appliances need current of widely different values to operate properly.
2. In series arrangement, when one component fails, the circuit is broken and none of the components works.
3. All electrical appliances work at a constant voltage. But in series circuit, the current is constant throughout the electric circuit and potential is different across the different components. So, series arrangement is not suitable for domestic circuits.

42. Name the physical quantity which is (i) same (ii) different in all the bulbs when three bulbs of:

(a) same wattage are connected in series.

(b) same wattage are connected in parallel.

(c) different wattage are connected in series.

(d) different wattage are connected in parallel.

Answer. (a) For identical bulbs in series- same current, same potential difference.

(b) For identical bulbs in parallel- same potential difference, different current.

(c) For unidentical bulbs in series- same current, different potential difference.

(d) For unidentical bulbs in parallel- different current, same potential difference.

43. Two devices of rating 44 W, 220 V and 11 W, 220 V are connected in series. The combination is connected across a 440 V mains. The fuse of which of the two devices is likely to burn when the switch is ON? Justify your answer.

Answer.



Using $P = \frac{V^2}{R}$

$$R_1 = \frac{V^2}{P_1} = \frac{220 \times 220}{44} = 1100 \Omega$$

$$R_2 = \frac{V^2}{P_2} = \frac{220 \times 220}{11} = 4400 \Omega$$

Equivalent resistance in series

$$R_S = R_1 + R_2 = 1100 + 4400 = 5500 \Omega$$

Current, $I = \frac{V}{R_S} = \frac{440}{5500} = 0.08 \text{ A}$

According to Joule's law of heating

$$H_1 = I^2 R_1 t$$

$$= (0.08)^2 \times 1100 \times 1 = 7.04 \text{ J}$$

$$H_2 = I^2 R_2 t$$

$$= (0.08)^2 \times 4400 \times 1 = 28.16 \text{ J}$$

$$\Rightarrow H_2 > H_1$$

44. Five resistors are connected in a circuit as shown. Find the ammeter reading when circuit is closed.

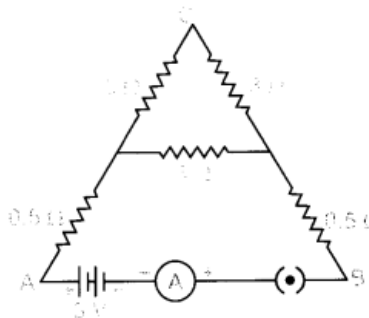

Answer.

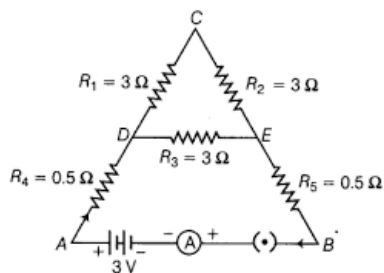

R_1 and R_2 are in series,

$$R_{S_1} = R_1 + R_2 = 3 + 3 = 6 \Omega$$

R_{S_1} and R_3 are in parallel,

$$\frac{1}{R_p} = \frac{1}{R_{S_1}} + \frac{1}{R_3} = \frac{1}{6} + \frac{1}{3} = \frac{1}{2}$$

$$R_p = 2 \Omega$$

R_4 , R_p and R_5 are in series,

$$R_S = R_4 + R_p + R_5$$

$$= 0.5 + 2 + 0.5 = 3 \Omega$$

Current, $I = \frac{V}{R_S} = \frac{3}{3} = 1 \text{ A}$

45. Study the circuit shown in which three identical bulbs B_1 , B_2 and B_3 are connected in parallel with a battery of 4.5 V.

- (i) What will happen to the glow of other two bulbs if the bulb B_3 gets fused?
 (ii) If the wattage of each bulb is 1.5 W, how much reading will the ammeter A show when all the three bulbs glow simultaneously?
 (iii) Find the total resistance of the circuit.

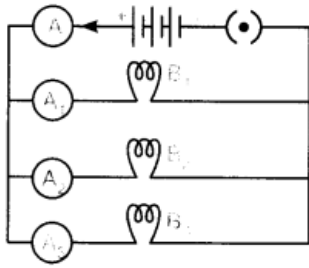

Answer.

- (i) The glow of other two bulbs remains the same.
 (ii) In parallel combination, potential difference across each resistance will remain same.

So, potential across each bulb = 4.5 V

Wattage of each bulb = 1.5 W

Using, $P = VI$

$$\text{For bulb } B_1, \quad I_1 = \frac{P}{V} = \frac{1.5}{4.5} = \frac{1}{3} \text{ A}$$

$$\text{For bulb } B_2, \quad I_2 = \frac{1.5}{4.5} = \frac{1}{3} \text{ A}$$

$$\text{For bulb } B_3, \quad I_3 = \frac{1.5}{4.5} = \frac{1}{3} \text{ A}$$

$$\begin{aligned} \text{Total current;} \quad I &= I_1 + I_2 + I_3 \\ &= \frac{1}{3} + \frac{1}{3} + \frac{1}{3} = \frac{3}{3} = 1 \text{ A} \end{aligned}$$

So, potential across each bulb = 4.5 V

\therefore Resistance of each bulb,

$$R = \frac{V^2}{P} = \frac{4.5^2}{1.5} = 13.5 \Omega$$

So, equivalent resistance of parallel combination

$$\begin{aligned} \frac{1}{R_p} &= \frac{1}{R_1} + \frac{1}{R_2} + \frac{1}{R_3} = \frac{1}{R} + \frac{1}{R} + \frac{1}{R} = \frac{3}{R} \\ R_p &= \frac{R}{3} = \frac{13.5}{3} = 4.5 \Omega. \end{aligned}$$

Wattage of each bulb = 1.5 W

Therefore, when all the three bulbs glow simultaneously, the ammeter A shows 1 A reading.

(iii) Potential difference across each bulb = 4.5 V Wattage of each bulb = 1.5 W

\therefore Resistance of

46. A circuit is shown in the diagram given below.

- (a) Find the value of R.
 (b) Find the reading of the ammeter.
 (c) Find the potential difference across the terminals of the battery.

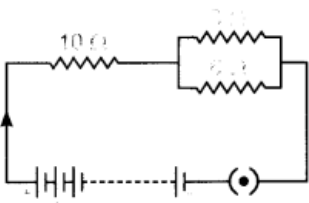

Answer.

(a) Potential difference across 6 Ω = 12 V

\therefore Current through 6 Ω ,

47. Consider the circuit shown in the diagram. Find the current in 3Ω resistor.

Answer.

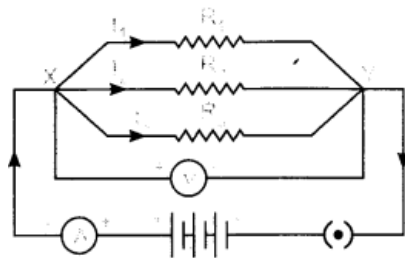

R_p and 10Ω are connected in series. So,

$$R_s = R_p + R_3 = 2 + 10 = 12\Omega$$

Total current in the circuit,

$$I = \frac{V}{R_s} = \frac{12}{12} = 1\text{ A}$$

Potential difference across, $R_p = IR_p = 1 \times 2 = 2\text{ V}$

So, Potential difference across, $3\Omega = 2\text{ V}$

Current through 3Ω , $I_1 = \frac{V}{R_1} = \frac{2}{3} = 0.67\text{ A}$

48. Study the I-V graph for four conductors A, B, C and D having resistance R_A, R_B, R_C and R_D respectively, and answer the following questions:

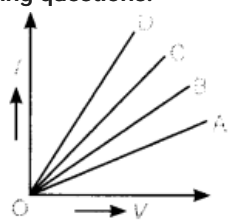

(i) Which one of these is the best conductor?

(ii) If all the conductors are of same length and same material, which is the thickest?

(iii) If all the conductors are of same thickness and of same material, which is the longest?

(iv) If the dimensions of all the conductors are identical, but

their materials are different which one would you use as (a) resistance wire (b) connecting wire?

(v) Which one of the following relations is true for these conductors?

(a) $R_A > R_B > R_C > R_D$ (b) $R_A < R_B < R_C < R_D$

(c) $R_A = R_B = R_C = R_D$ (d) $R_A = R_B < R_C < R_D$

(vi) If conductors A and B are connected in series and I-V graph is plotted for the combination, its slope would be

(a) less than that of A. (b) more than that of A.

(c) between A and B. (d) more than that of D.

(vii) If conductors C and D are connected in parallel and I-V graph is plotted for the combination, its slope would be

(a) lesser than that of A. (b) more than that of D.

(c) between C and D. (d) between B and C.

Answer.

Slope = $\frac{I}{V} = \frac{I}{R}$ is least for R_A .

So, $R_A > R_B > R_C > R_D$

(i) D is the best conductor, as it has the least resistance among A, B, C and D.

(ii) Area of cross-section $\propto \frac{1}{\text{Resistance}}$. So, D is the thickest.

(iii) Resistance \propto length. So, A is the longest.

(iv)(a) Resistance wire – A (b) Connecting wire – D

(v) Option (a) is correct.

(vi)(a) In series, resistances are added. ($R_s = R_A + R_B$). So, in the given I-V graph, slope of series combination would be less than that of A.

(vii)(b) In parallel combination, the equivalent resistance is less than the least value resistance in the circuit. So, in the given I-V graph, slope for parallel combination is more than that of D

Class 10 Science Electricity Short Answer Type Question [I] [2 Marks] – Year 2010

49. In an experiment to study the relation between the potential difference across a resistor and the current through it, a student recorded the following observations:

Potential difference, V (volts)	1.0	2.2	3.0	4.0	6.4
Current, I (amperes)	0.1	0.2	0.6	0.4	0.6

On examine the above observations, the teacher asked the student to reject one set of readings as the values were out of agreement with the rest. Which one of the above sets of readings can be rejected? Calculate the mean value of resistance of the resistor based on the remaining four sets of readings.

Answer. The third reading for $V = 3.0$ volt and $I = 0.6$ A will be rejected as it has larger deviation from the rest of the readings.

The value of resistance in the other four observations will be I (using $R = V/I$) 10Ω , 11Ω , 10Ω and 10.67Ω .

So, the mean value of resistance = $\frac{41.67}{4} = 10.417 = 10.42\Omega$

Class 10 Science Electricity Long Answer Type Questions [5 Marks] – Year 2010

50. Explain with the help of a labelled circuit diagram, how will you find the resistance of a combination of three resistors, of resistance R_1 , R_2 and R_3 joined in parallel. Also mention how will you connect the ammeter and the voltmeter in the circuit while measuring the current in the circuit and the potential difference across one of the three resistors of the combination.

Answer. Parallel Combination:

1. Connect the three given resistor R_1 , R_2 and R_3 in parallel between the point XY with a battery, a plug key and ammeter in series as shown in figure.

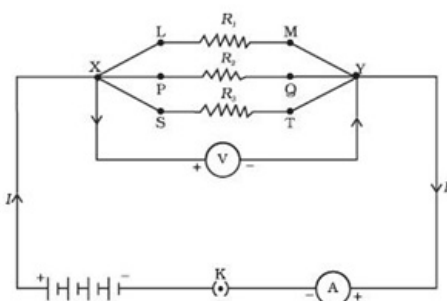

2. Connect voltmeter in parallel with these resistors between the terminals X and Y.
3. Close the key and note the ammeter and voltmeter reading. Ammeter shows the total current drawn by the parallel combination of these resistors while voltmeter shows the voltage applied across the combination.
4. Using Ohm's law, find the equivalent resistance of the combination, i.e. equivalent resistance,

$$R = \frac{\text{Voltmeter reading}}{\text{Ammeter reading}}$$

Thus, in parallel circuit,

$$\begin{aligned} I &= I_1 + I_2 + I_3 \\ \frac{V}{R_p} &= \frac{V}{R_1} + \frac{V}{R_2} + \frac{V}{R_3} \\ \Rightarrow \frac{1}{R_p} &= \frac{1}{R_1} + \frac{1}{R_2} + \frac{1}{R_3} \end{aligned}$$

To find the current flow through any one of the resistor, ammeter will be connected in series with that resistor and to measure the potential difference across that resistor, voltmeter must be connected in parallel with that resistor as shown.

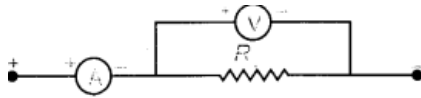

51. Derive the expression for the heat produced due to a current I flowing for a time interval ' t ' through a resistor ' R ' having a potential difference ' V ' across its ends. With which name is the relation known? How much heat will an instrument of 12 W produce in one minute if it is connected to a battery of 12 V?

Answer. Heat produced in a conductor: Consider a wire AB having a resistance ' R ' connected across the terminals of a cell. Let V be the potential difference applied by cell across the ends of a wire.

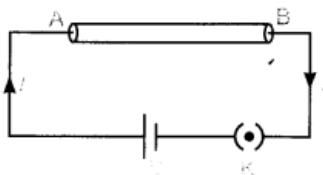

Let W be the work done in carrying the charge q across the conductor, then

$$V = \frac{W}{q} \text{ or } W = V \times q \quad (i)$$

but $q = I \times t$

$$\text{So, } W = V \times It \quad (ii)$$

This work done will appear in the form of heat produced in the wire, i.e.

$$H = VIt \quad (iii)$$

Using Ohm's law, $V = IR$

$$\text{So, } H = (IR) It = I^2Rt$$

This is the expression for the heat produced in the wire. This is called Joule's law of heating.

Heat produced in one minute

$$H = P \times t = 12 \text{ W} \times 60 \text{ s} = 720 \text{ J}$$

52. Deduce the expression for the equivalent resistance of the parallel combination of three resistors R_1 , R_2 and R_3

Consider the following electric circuit:

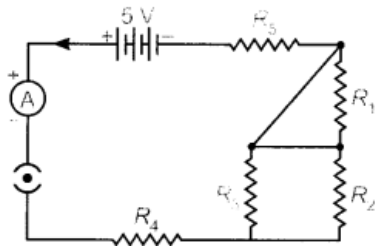

- (a) Which two resistors are connected in series?
 (b) Which two resistors are connected in parallel?
 (c) If every resistor of the circuit is of $2\ \Omega$, what current will flow in the circuit?

Answer. Consider the following parallel circuit shown below: Let I_1 , I_2 and I_3 be the current flow through the resistor R_1 , R_2 and R_3 connected in parallel.

Using Ohm's law, current through each resistor is

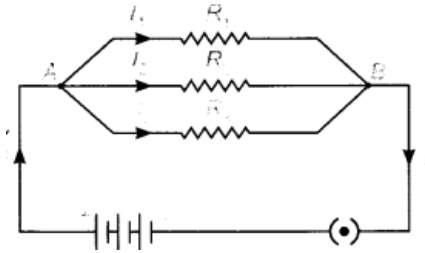

$$I_1 = \frac{V}{R_1}, I_2 = \frac{V}{R_2} \text{ and } I_3 = \frac{V}{R_3}$$

Let their equivalent resistance be R_p then

$$V = IR_p \Rightarrow I = \frac{V}{R_p}$$

Total current through the circuit is

$$I = I_1 + I_2 + I_3$$

or
$$\frac{V}{R_p} = \frac{V}{R_1} + \frac{V}{R_2} + \frac{V}{R_3}$$

or
$$\frac{V}{R_p} = V \left(\frac{1}{R_1} + \frac{1}{R_2} + \frac{1}{R_3} \right)$$

or
$$\frac{1}{R_p} = \frac{1}{R_1} + \frac{1}{R_2} + \frac{1}{R_3}$$

Class 10 Science Electricity Very Short Answer Type Questions [1 Mark] – Year 2009

53. Two resistors of $10\ \Omega$ and $15\ \Omega$ are connected in series to a battery of $6\ \text{V}$. How can the values of current passing through them be compared?

Answer. In series, same current flows through each resistor. So, ratio of current is $1 : 1$.

54. A wire of resistance $20\ \Omega$ is bent to form a closed square. What is the resistance across a diagonal of the square?

Answer.

Resistance of each side of a square = $\frac{20}{4} = 5\ \Omega$

$$\begin{aligned} \frac{1}{R_{eq}} &= \frac{1}{R_{AB} + R_{BC}} + \frac{1}{R_{AD} + R_{DC}} \\ &= \frac{1}{5 + 5} + \frac{1}{5 + 5} \\ &= \frac{1}{10} + \frac{1}{10} = \frac{1}{5} \end{aligned}$$

$\therefore R_{eq} = R_{AC} = R_{BD} = 5\ \Omega$

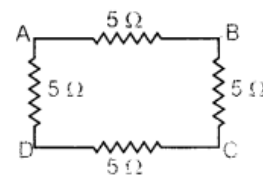

Class 10 Science Electricity Short Answer Type Questions[I] [2 Marks] – Year 2009

55. Draw a schematic diagram of an electric circuit consisting of a battery of five 2 V cells, a 20 Ω resistor, a 30 Ω resistor, a plug key, all connected in series. Calculate the value of current flowing through the 20 Ω resistor and the power consumed by the 30 Ω resistor.

Answer. $R_{eq} = 20 + 30 = 50 \Omega$

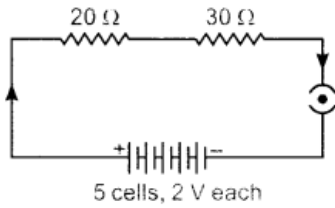

Current through both 20 Ω and 30 Ω = $I = 10/50$

= 0.2 A

Power consumed by 30 Ω = $I^2R = (0.2)^2 \times 30 = 1.2W$

56. A piece of wire of resistance 20 Ω is drawn out so that its length is increased to twice its original length. Calculate the resistance of the wire in the new Situation.

Answer.

Using, $R = \frac{\rho l}{A}$,

We have, $\frac{R_1}{R_2} = \frac{l_1}{A_1} \cdot \frac{A_2}{l_2}$

Given: $l_2 = 2l_1$

Volume of material will be conserved.

So, $A_1 l_1 = A_2 l_2$

$\therefore \frac{A_1}{A_2} = \frac{l_2}{l_1} = 2$

$\frac{R_1}{R_2} = \frac{l_1}{l_2} \cdot \frac{l_1}{l_2} = \frac{l_1^2}{l_2^2} = \frac{1}{4}$

$\therefore R_2 = 4R_1 = 80 \Omega$

57. What is an electric circuit? Distinguish between an open and a closed circuit.

Answer. An arrangement for maintaining the continuous flow of electric current by the electrical energy source through the various electrical components connected with each other by conducting wires is termed as electric circuit.

An open circuit does not carry any current, while a closed circuit carries current.

Class 10 Science Electricity Short Answer Type Questions[II] [3 Marks] – Year 2009

58. Two resistors with resistances 5Ω and 10 Ω are to be connected to a battery of emf 6 V so as to obtain:

(i) minimum current

(ii) maximum current

(a) How will you connect the resistances in each case ?

(b) Calculate the strength of the total current in the circuit in the two cases.

Answer.

(a) As current is inversely proportional to resistance for the same voltage. So, to get maximum current, the equivalent resistance has to be less. This means the resistors must be connected in parallel.

To get minimum current, the equivalent resistance has to be greater as

$I \propto \frac{1}{R}$. This means the resistors must be connected in series.

$$(b) \quad \frac{1}{R_p} = \frac{1}{5} + \frac{1}{10} = \frac{2+1}{10}$$

$$\Rightarrow R_p = \frac{10}{3} \Omega$$

$$\therefore I_{max} = \frac{V}{R_p} = \frac{6}{10/3} = \frac{18}{10} = 1.8 \text{ A}$$

$$R_s = R_1 + R_2 = 10 + 5 = 15 \Omega$$

$$\therefore I_{min} = \frac{V}{R_s} = \frac{6}{15} = \frac{2}{5} = 0.4 \text{ A}$$

59.(a) Define the term 'volt'.

(b) State the relation between work, charge and potential difference for an electric circuit.

Calculate the potential difference between the two terminals of a battery if 100 J of work is required to transfer 20 C of charge from one terminal of the battery to the other.

Answer.

(a) When 1 joule of work is done in carrying 1 coulomb of charge, from infinity to a point in the electric field, then potential at that point is called 1 volt.

(b) Potential difference, $V = \text{Work done on unit charge} = W/q$

Work is 100 J, $q=20\text{C}$

Potential difference, $V=W/q=100/20=5\text{V}$

60.(a) Define the term 'coulomb'.

(b) State the relationship between the electric current, the charge moving through a conductor and the time of flow.

Calculate the charge passing through an electric bulb in 20 minutes if the value of current is 200 mA.

Answer.

$$I = \frac{q}{t}$$

$$t = 20 \times 60 = 1200 \text{ seconds,}$$

$$I = 200 \text{ mA} = 200 \times 10^{-3} \text{ A}$$

$$\text{Charge passing} = q = It = 200 \times 10^{-3} \times 1200 = 240 \text{ C}$$

(a) When 1 A current flows across the wire in 1 second, the charge transfer across its ends is said to be 1 coulomb.

(b) The relationship between the electric current I , the charge q and time t is

61.(a) How is the direction of electric current related to the direction of flow of electrons in a wire?

(b) Calculate the current in a circuit if 500 C of charge passes through it in 10 minutes.

Answer.

(a) Conventional direction of electric current is opposite to the direction of flow of electrons in a wire.

(b) $q = 500 \text{ C}$, $t = 10 \times 60 = 600 \text{ s}$

$I = 500/600 = 5/6 \text{ A}$

62.(a) Two resistors R_1 and R_2 may form (i) a series combination or (ii) a parallel combination, and the combination may be connected to a battery of 6 volts. In which

combination, will the potential difference across R_1 and across R_2 be the same and in which combination, will the current through R_1 and through R_2 be the same?

(b) For the circuit shown in this diagram, calculate

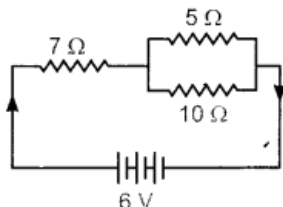

(i) the resultant resistance.

(ii) the total current.

(iii) the voltage across $7\ \Omega$ resistor.

Answer. (a) Potential difference across R_1 and R_2 is same in parallel combination of R_1 and R_2 and the current through R_1 and R_2 will be same when they are connected in series.

(b) (i) $5\ \Omega$ and $10\ \Omega$ are in parallel.

$$\text{So, } \frac{1}{R_1} = \frac{1}{5} + \frac{1}{10} = \frac{10+5}{50} = \frac{15}{50}$$

$$\Rightarrow R_1 = \frac{50}{15}\ \Omega = 3.33\ \Omega$$

Since, $7\ \Omega$ is in series with R_1

$$R_{eq} = R_1 + 7 \\ = 3.33 + 7 = 10.33\ \Omega$$

$$(ii) \text{ Total current drawn} = \frac{V}{R_{eq}}$$

$$I = \frac{6}{10.33} = 0.58\ \text{A}$$

$$(iii) \text{ Voltage across } 7\ \Omega \text{ resistor} = I \times 7 = 0.58 \times 7 = 4.06\ \text{V}$$